

# Sliding doors

GÜNTHER-TORE

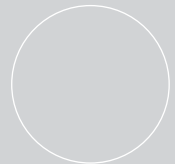

The outstanding alternative

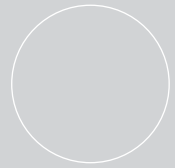
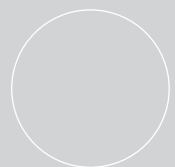

Smoothly operating sliding doors  
robust and very long-lived.



Sliding doors

# Sliding doors



*The needs of our customers are our passion. Developing innovative technologies of highest quality and bringing it to*

*the market is our drive.*

*Both of these aspects unify the Günther Group across all disciplines and limits. The same is true for the uncompromising will to succeed. The courage to put new ideas quickly into practice. And last but not least, the ambition to solve any problem with perfection we are confronted with.*

*Our largest asset, however, is our customers' great confidence. Confidence in our capabilities, our experience, and in our readiness for action. Confidence in the quality and reliability of our products.*

*We owe it to this confidence that today all companies of the Günther group are leaders in their respective markets. We are pleased about it. We are proud of it.*

*And this success encourages us to continue to assist our customers with the best individual and progressive solutions of highest quality.*

*We are there for you.*

*Yours sincerely,*

*Dr.-Ing. Wolfgang Günther*



First-class solutions  
at a top price

Where do you still find a "truly excellent price/performance ratio" today? We have always applied extremely high standards in this respect. In our experience, a "truly excellent price/performance ratio" is offered by a very adaptable, premium-quality product, combined with excellent service – obviously at a convincing price all-round. A Günther door is a good example.

Each individual Günther door represents premium quality down to the last detail. The doors are manufactured precisely according to customer specification using high-quality materials and components. They are expertly built based on the know-how and the experience from about 30 years of successful industrial door construction. They naturally come in the current design of our time, accompanied by top service. From planning and costing via production, installation and commissioning to regular maintenance. In

renovation projects, we even offer disposal of your old doors, even if they did not originate from us.



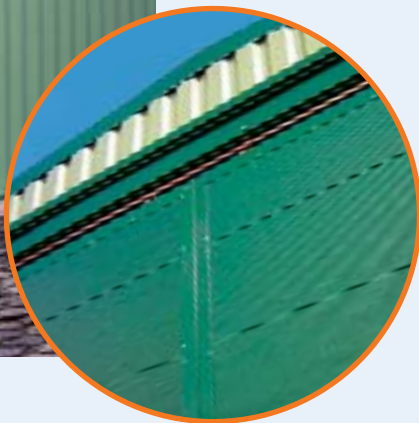

## Robust, long-lived technology for any application

If your door has to open and close quickly and you do not have a lot of space to waste, sliding doors from Günther will always be an excellent alternative at a convincing price. The extremely robust Günther sliding doors can be opened manually without much effort, or they can be equipped with a powerful electric drive. The installation requires very little space around the lintel. For opening and closing, little additional clearance is required in front or behind your door opening.

Günther sliding doors are specially designed for long-term operation even under harsh conditions and are universally applicable. The durability of the doors is a result of the expertly processed quality materials. Another reason is that only very few moving parts are used, which means that wear and tear is minimised.

Günther guarantee. We offer a two-year guarantee for wear and tear parts, electrical components, and moving and stationary parts of your durable Günther door.



1 Classic model, RAL 6005- external operation, two wings

2 Classic model, RAL 6005- internal operation, single wing

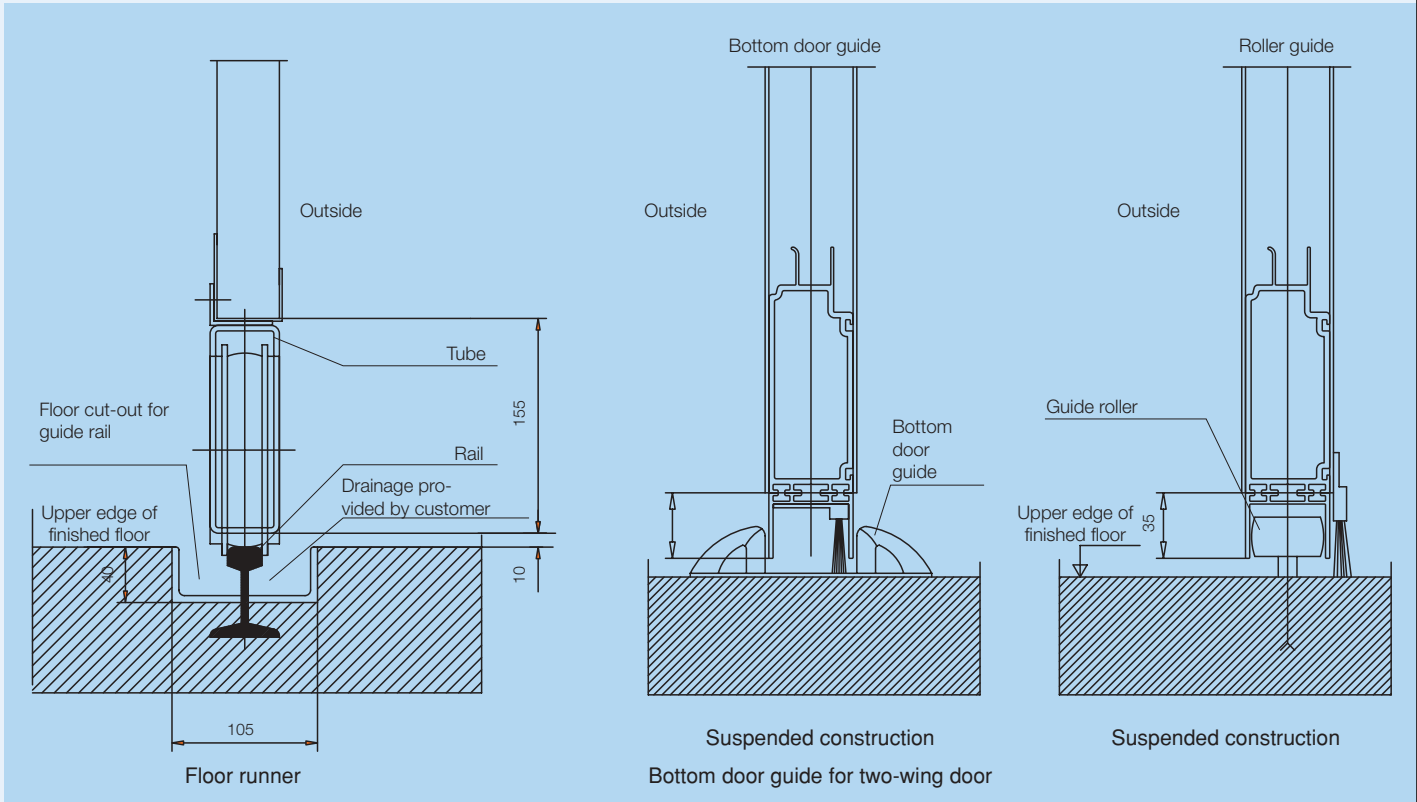

### Further benefits of Günther technology



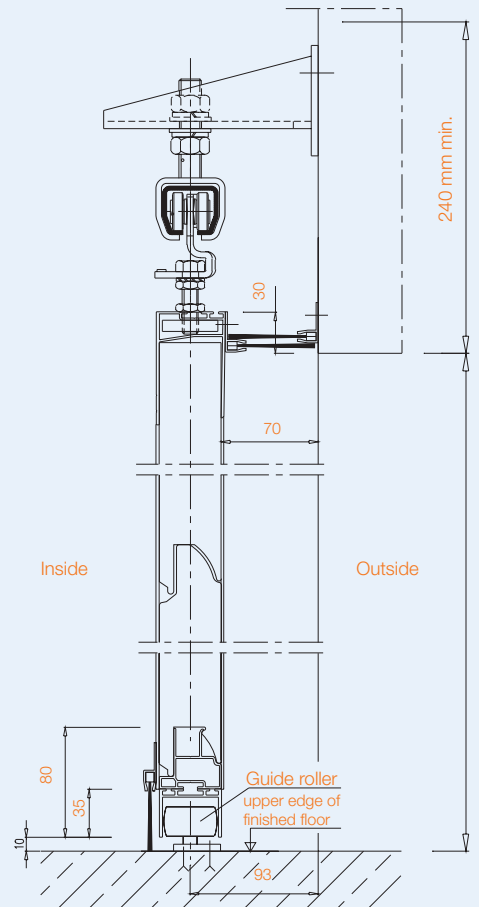
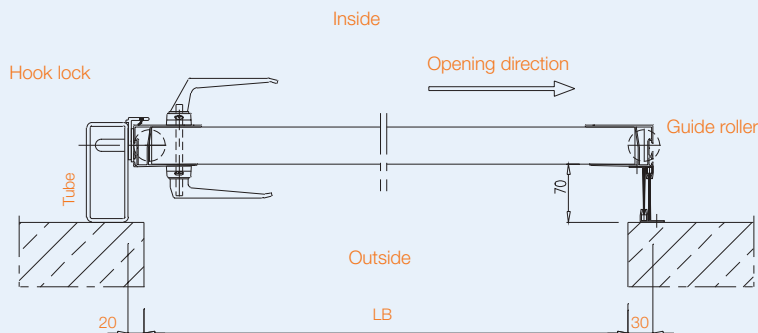

Your individual Günther sliding door can be guided in three different ways along the floor, as shown in the drawings above. Depending on the task and the implementation, the available options are guide rail (top left), "tortoise" guide system (top centre) or guide rollers (top right).

Three different, powerful electric motors are available for moving your robust Günther sliding door: a "KG S 800 N" ceiling drive, a "SM 40" sliding door drive with toothed rack mounted on the door leaf, or a sliding door drive with chain guide.

Light barriers and traffic lights are available as optional accessories to ensure optimum integration of your automatic Günther sliding door into your workflow.

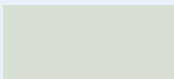
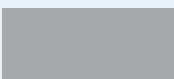
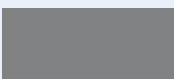
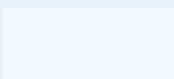

### Standard panel colours (RAL)

3000 	5009 	5010 
6005 	8014 	9002 
9006 	9007 	9016 

### Wide range of installation and design options

Your new Günther sliding door is manufactured from first-class steel sandwich panels with a thickness of 45 mm, or with a frame rung construction made from high-quality aluminium. The doors may feature one or more wings, with the opening direction matching your requirements. Each variant can optionally be installed on an internal or external surface.

Depending on your requirements, the doors can be supplied with generous areas of glazing or with optimum thermal insulation. For frame rung constructions, single or double wall versions with individual field sizes are available. And last, but not least, a wide range of colour options is available. Günther-Tore can powder-coat your sliding door in any colour of the current RAL range.

As a convenient optional extra, your Günther sliding door can be equipped with a pass door (provided the floor sleeper is sufficiently high).

### User-friendly, modern suspension

Almost all current Günther sliding doors are guided in a tubular rail using dual pairs of rollers with ball bearings. Only very large special formats are today still manufactured as so-called floor runners. In this case, your Günther sliding door features rollers running inside a guide rail that is sunk into the floor. For all door types, generously dimensioned ball bearings ensure the typical smooth and gentle movement with little wear of your Günther sliding door.

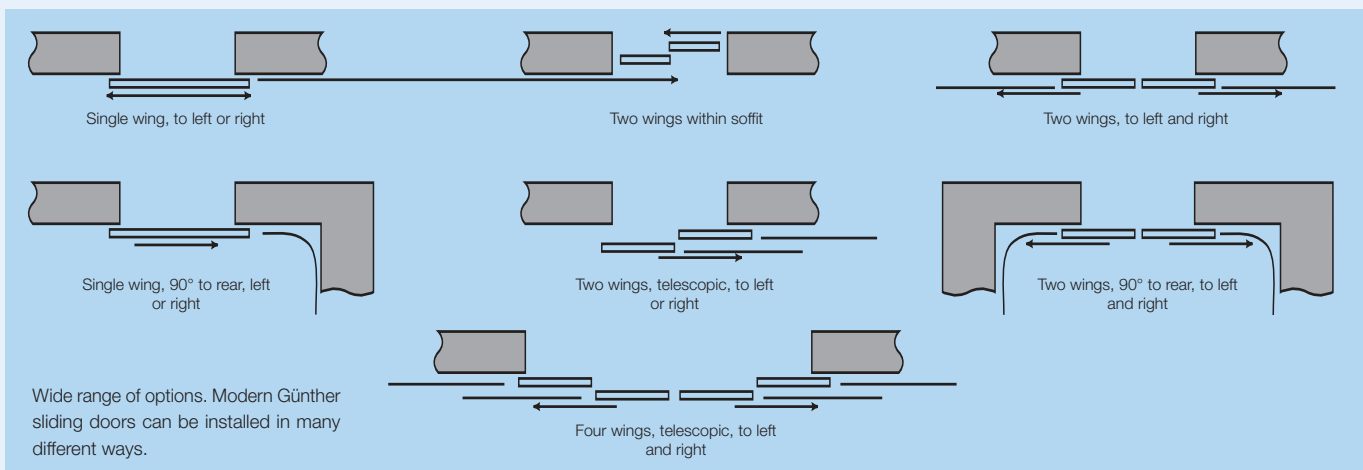

A strong group



Main Factory Neunkirchen

Günther-Tore GmbH  
 Metallwerk  
 Industriegebiet  
 D-56479 Neunkirchen  
 Tel. +49 (0) 64 36/601-0  
 Fax +49 (0) 64 36/601-130  
[www.guenther-tore.de](http://www.guenther-tore.de)  
[info@guenther-tore.de](mailto:info@guenther-tore.de)

Sliding doors

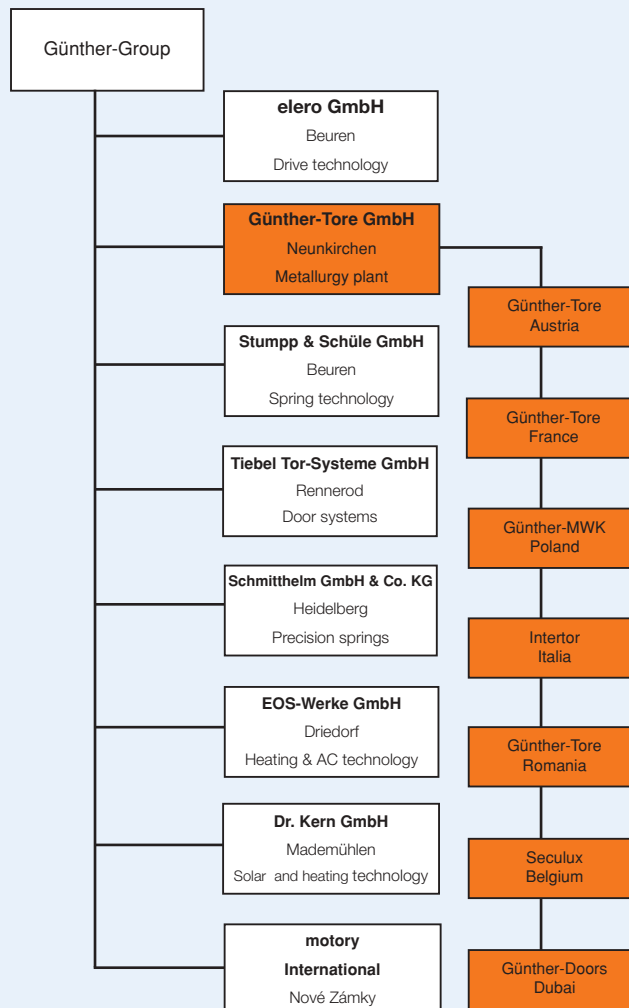

Your door specialist: